



In our efforts to expand the Access Floor Industry into new market sectors, it has become apparent that solutions for wet areas are an essential piece of our product offerings. Due to this need, Tate Access Floors is pleased to announce that we have developed recommended solutions for these applications.

Attached you will find four options for either a waterproof or a water resistant Access Floor installation. Choosing the one that meets your needs will depend on the degree of moisture the floor will be exposed to and the degree of access required for that area. We have attached test reports that will help you in making your selection. Many of the accessory items required can be found in Tate's new Price List dated February 1st, 2004. We have also listed the manufacturer's information including their part numbers if you choose to procure the items directly from them.

Although we are presenting four solutions, please remember that these may not be the only acceptable options for wet area installations. If you have done installations successfully with alternate methods, we would appreciate the opportunity to hear about them.

If you have any questions or comments, please contact your Inside Sales representative, or Tate's Technical Hotline at 1-800-231-7788.

Wet Area Dynamic Load Test

Date: April 16, 2003

Products Tested: Standard Masking Tape
McMaster Carr Clean Room Tape #76505A437, #76505A431 & #76505A425
McMaster Carr Outdoor Weatherproofing Tape #1228A56

Panel Type: CCN1000 with .125" VPI with Top Set Trim

Understructure: Bolted Stringer

The following test was performed in accordance with the "Recommended Test Procedures for Access Floors: Section 3 Rolling Loads" as published by the Cisca organization as described herein:

Tate CCN1000 panels laminated with .125" VPI tile and top set trim were supported on the above referenced understructure in a three panel mock-up and mounted on a rolling load simulator. The seam between two of the panels were covered with standard masking tape. The second seam was covered with McMaster Carr Clean Room Tape #76505A437 (76505A431 and 76505A425 are similar, but different colors). The final seam was covered with McMaster Carr Outdoor Weatherproofing Tape #1228A56. The mock-up was subjected to the following test:

A load of 600 lbs. was applied to the panel surface via a 6" dia. X 1-1/2" alathane wheel at a rolling load rate of 100 ft./minute for a duration of 10,000 passes. The mock-up was examined after 500 passes and then at 100 pass intervals to evaluate the condition of the tapes.

The wheels were mounted to a cart arrangement and the load was verified by a Morehouse Force Ring Gauge (S/N 50554). The path of the wheel was selected to be down the center of the panel. The results are as follows:

Standard Masking Tape – Cracking at the seam was noted after 700 passes. Tape gradually deteriorated, but was still visible after 10,000 passes.

Clean Room Tape – Cracking at the seam was noted after 2300 passes. Tape gradually deteriorated, but was still visible after 10,000 passes.

Outdoor Weatherproofing Tape – Cracking at the seam was noted after 7000 passes. Tape gradually deteriorated, but was still visible after 10,000 passes.

Tested By: _____
Bill Shingler
Quality Systems Technician

Date: _____



Wet Area Leakage Test

Date: November 18, 2002
Products Tested: See Below
Panel Type: CCN1000
Understructure: Bolted Stringer

Mock-ups consisting of 4 panels each were assembled as indicated below. Neoprene gasket material was installed over panel seams per below diagram to create a water barrier. Eight ounces of water was poured into the barrier. The results are as follows:

<u>System Type</u>	<u>Degree of Leakage</u>
• Monolithic Soft Tile with Heat Welded Seams	None
• Monolithic Soft Tile with Cold Welded Seams	None
• Soft Tile with Top Set Trim and 1" wide Clean Room Tape over Seams McMaster Carr # 76505A437 (#76505A431 & #76505A425 are similar)	None
• Soft Tile with Top Set Trim and 2" wide Weatherproof Tape over Seams McMaster Carr # 1228A56	None
• Monolithic Soft Tile with firm Neoprene gasket on stringer, gravity held McMaster Carr # 93745K53 (gray)	Excessive
• Monolithic Soft Tile with firm Neoprene gasket on stringer, cornerlocked McMaster Carr # 93745K53 (gray)	Moderate
• Monolithic Soft Tile with soft Neoprene gasket on stringer, gravity held McMaster Carr # 93745K23 (black)	Moderate*
• Soft Tile with Top Set Trim in standard stringer system, no special steps taken	Excessive

*Although leakage was moderate, gasket tended to soak up and hold the water. This gasket is not recommended.

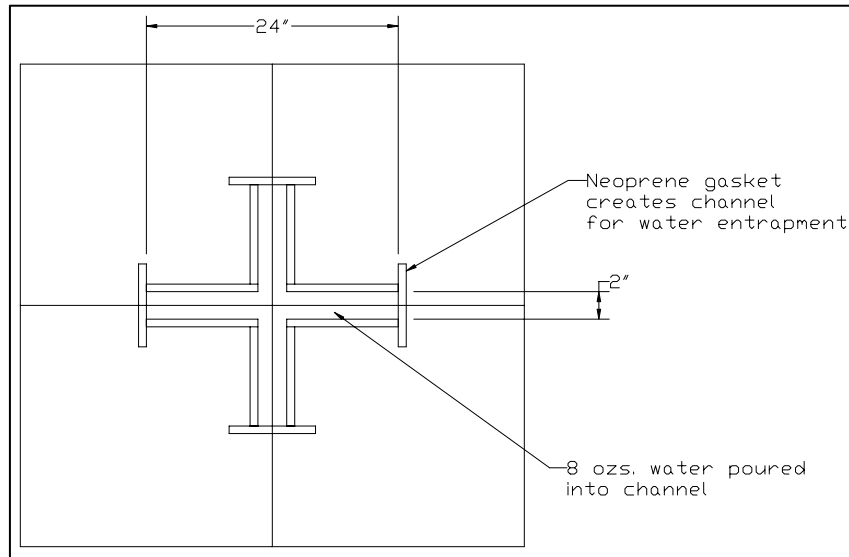

Tested By: _____
 Dan Catalfu
 Sr. Industrial Design Engineer

Date: _____

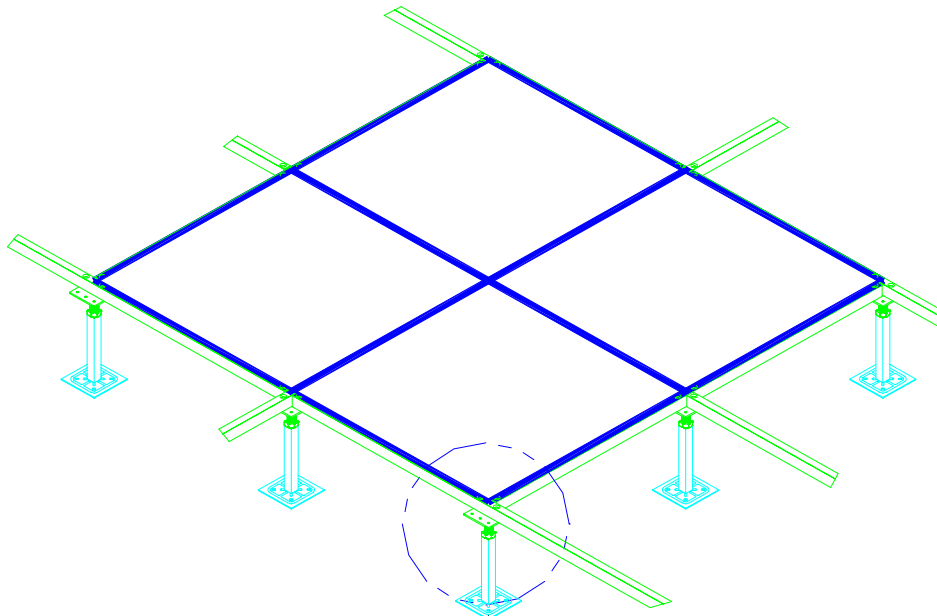

Tape will need to be routinely replaced to maintain waterproof system. Actual replacement intervals will depend on traffic and water exposure.

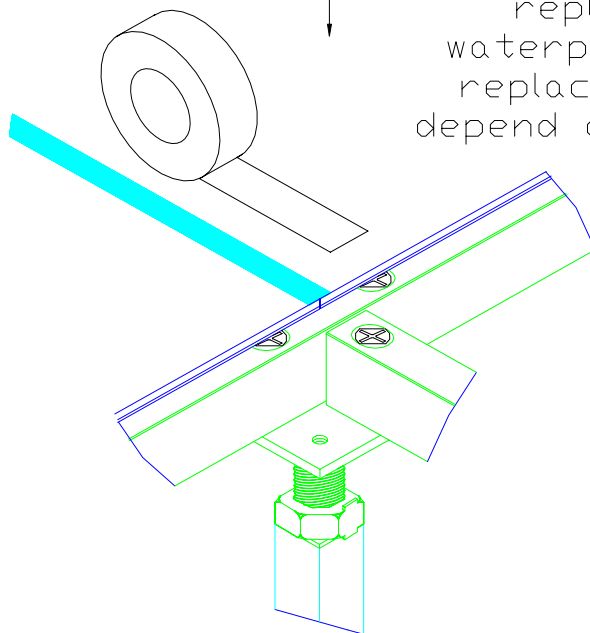

Field applied tape over seams with monolithic or top set trim vinyl or rubber tile.

- McMaster Carr #76505A437 - 1" wide blue
- McMaster Carr #76505A431 - 1" wide white
- McMaster Carr #76505A425 - 1" wide clear
- McMaster Carr #1228A56 - 2" wide clear



Welded Seams on Module for Wet Areas

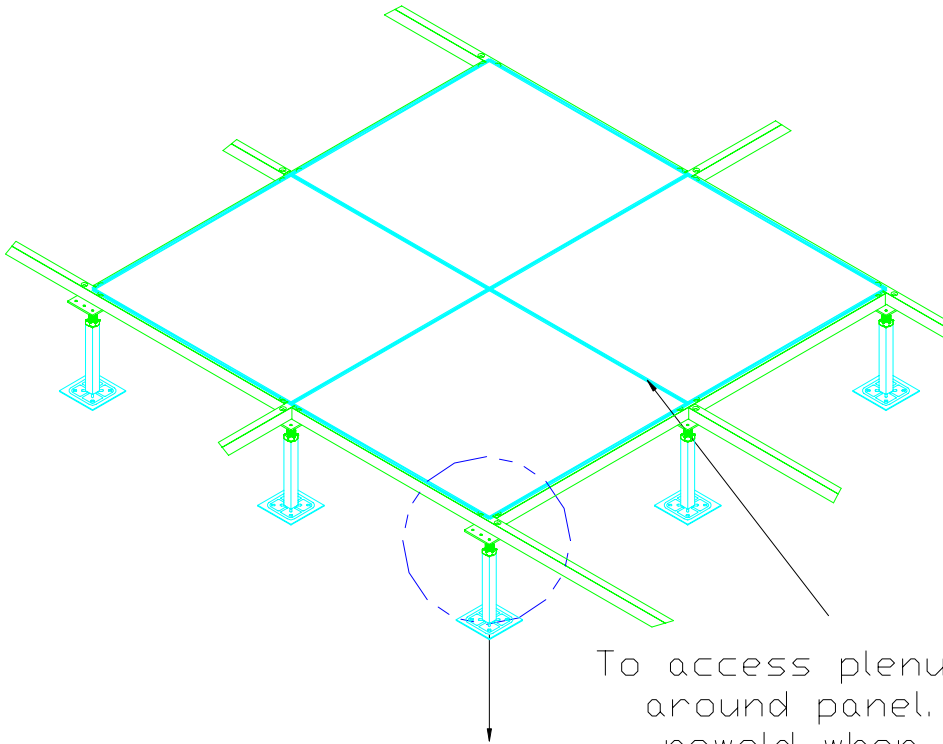

To access plenum, cut welds around panel. Clean and reweld when access is completed.

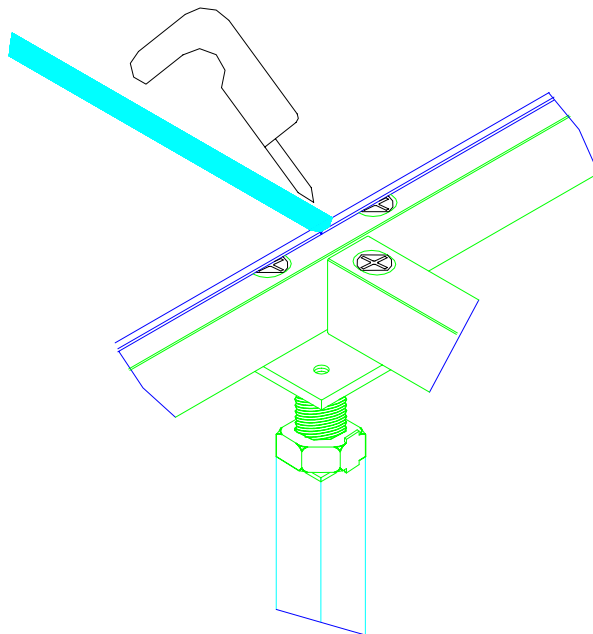

Heat or cold welded seam on module with vinyl or rubber tile, field welded. Specify monolithic tile with beveled edge.

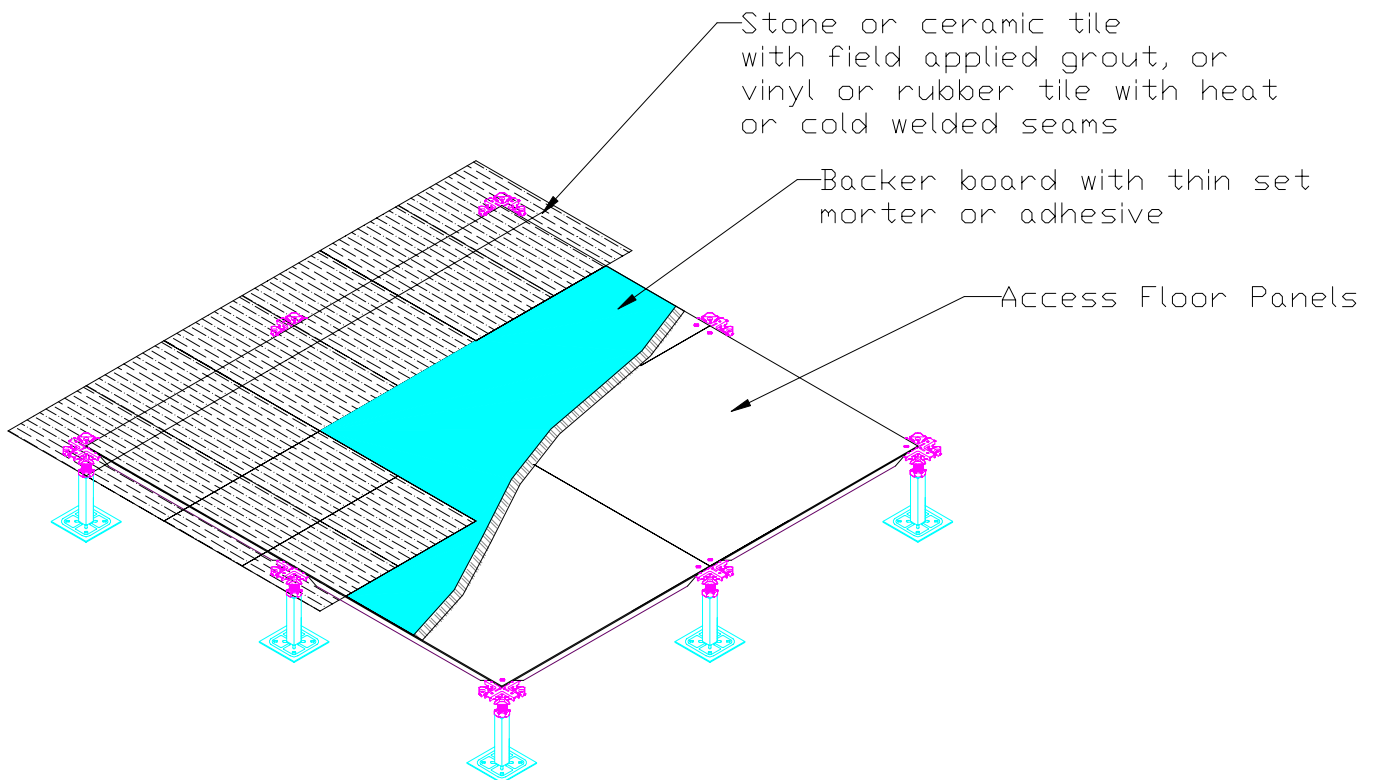

Suitable for use with virtually any conventional floor finish. In addition, provides a waterproof solution when used with the appropriate floor finish. This method does not allow access to the plenum.

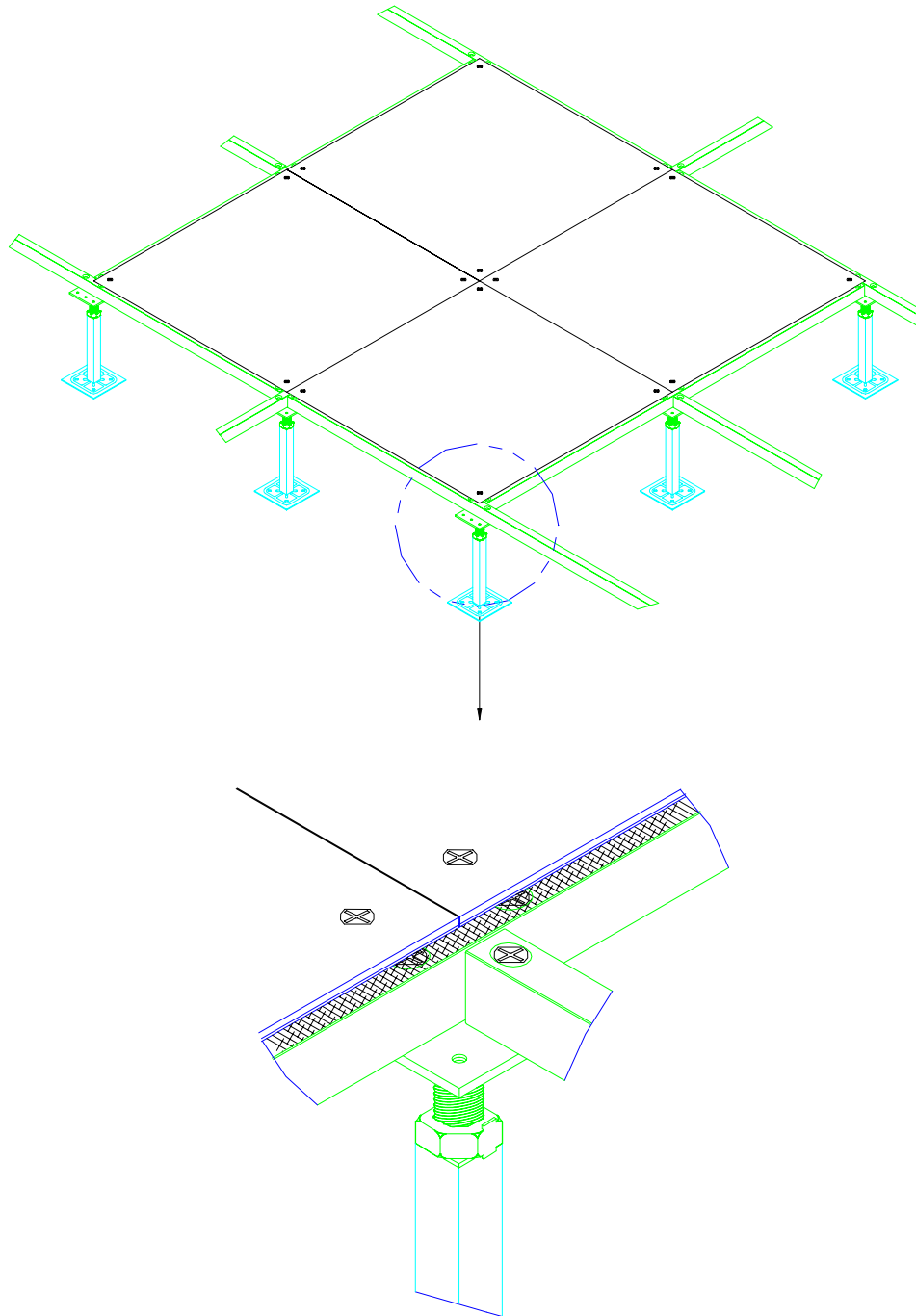

Field applied gasket on stringer with monolithic vinyl
or rubber tile. Install with Combo Screws.

(Water resistant, not waterproof)

McMaster Carr #93745K53 - 3/4" wide gray, firm