

BOTTOM VIEW WITH OPTIONAL AIR EXACT DAMPER

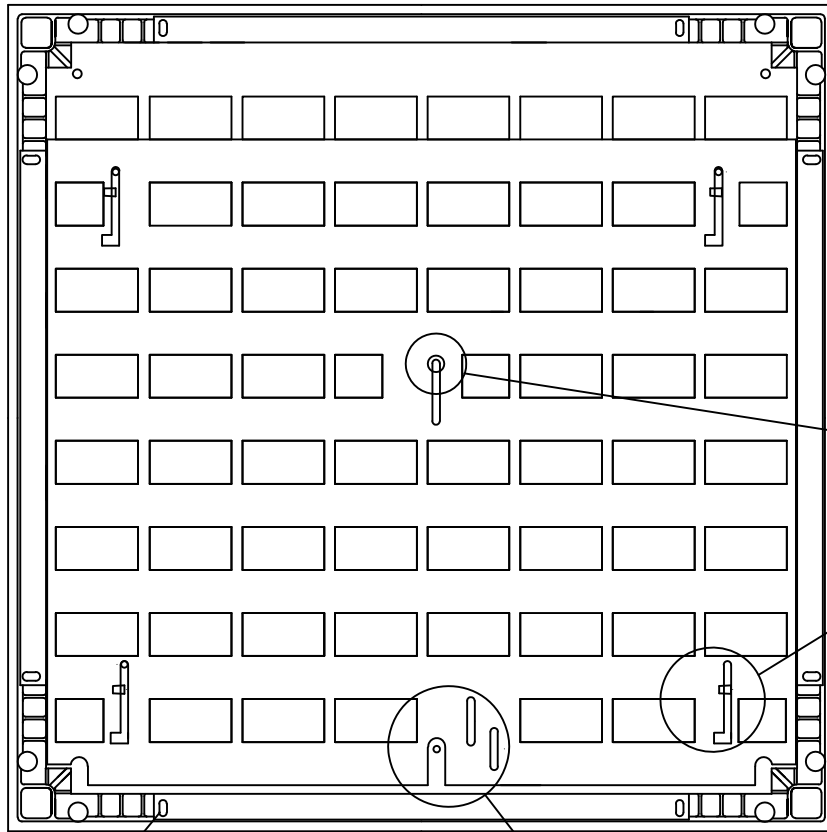

AIR EXACT DAMPER

General information

- Locking feature locks damper at desired setting from top.
- Easily disassembles for cleaning.
- Adjustable from top with standard T-handle allen wrench.
- Compatible with FF1250, FF3000 perforated panels and grates.
- Opening setting is clearly visible from top.
- Same standard 5/32" T-handle allen wrench for adjusting damper and locking it in place.
- Material: Aluminum alloy 5062.
- 55 slotted openings of approximately 0.94 cm X 0.44 cm.

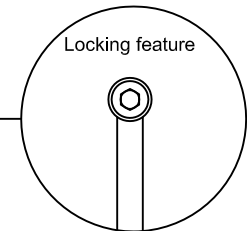

Tab for easy disassembly and cleaning

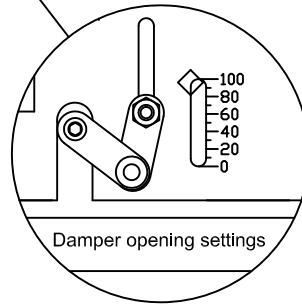

100 represents fully open
0 represents fully closed

DOWNWARD AIR FLOW PERFORMANCE

Chamfered Holes

Static Pressure (in H ₂ O)	FF 3000 Perforated No Damper	Damper Percent Open							
		20%	30%	40%	50%	60%	70%	80%	100%
Airflow in CFM									
.02	434	162	224	243	301	322	338	364	383
.04	646	249	319	384	412	464	486	520	558
.06	815	300	392	476	535	586	611	653	705
.08	951	355	462	549	609	667	722	774	853
.10	1081	393	512	605	698	773	827	879	960

Downward air flow performance is tested with 1/8" tile with standard 1,024 each 11/32" diameter perforation holes.